

Esempio di applicazione / Example of application / Exemplo de aplicação

#### FM 39-65

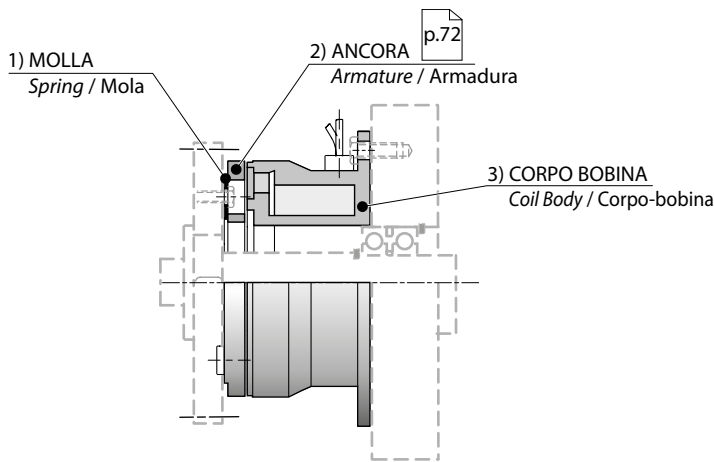

#### FM 80-230

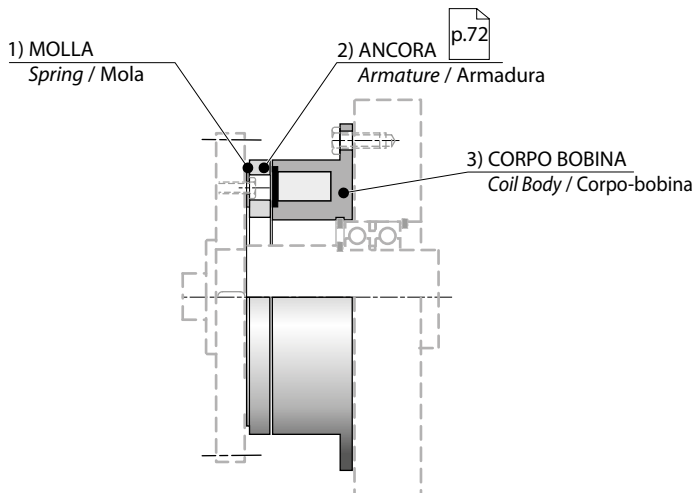

#### Caratteristiche / Characteristics / Características

TAGLIA SIZE TAMANHO	Coppia Nom. Statica Nom. Static Torque Torque nom. est. CU 1)	Tensione Nominale Nominal Voltage Tensão	Potenza assorbita Input Power Potência	nmax	Tempo inserzione Engagement time Tempo inserção	Tempo disinserzione Desengagement time Tempo disinserção	Mom. inerzia Ancora Mom. of inertia Armature Mom. de inércia Armadura	
	Nm	V (C.C - D.C)	W	rpm	ms	ms	10 <sup>-5</sup> kg*m <sup>2</sup>	
FM39	0.6	24	6	10000	15	3	0.140	0.05
FM45	0.9	24	6	10000	20	4	0.213	0.08
FM54	1.8	24	8	10000	25	5	0.666	0.11
FM65	3.6	24	10	10000	35	6	1.657	0.33
FM80	7.5	24	11.5	8000	35	10	4.2	0.8
FM100	15	24	16	6000	40	20	11.8	1.2
FM125	30	24	21	5000	60	30	47.2	2.3
FM150	60	24	28	4000	80	45	130	3.9
FM190	120	24	38	3000	100	60	480	7
FM230	240	24	45	3000	115	70	1370	13.3

1) Selezione del valore di coppia vedere pag. / Selection the torque value see page / Seleção do valor de torque página

p.64

## Freno elettromagnetico monodisco

Single disc pack electromagnetic brake / Freio eletromagnético monodisco

Dimensioni / Dimension / Dimensões

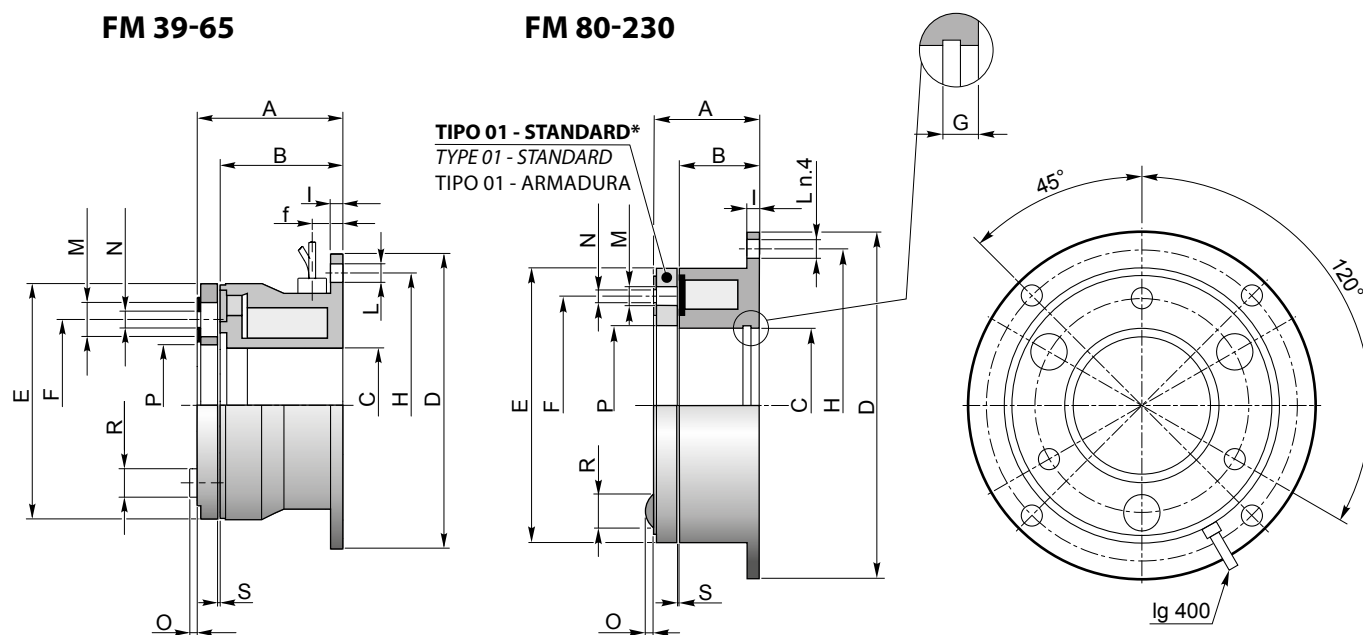

\* Altri tipi di ancora vedi / Other types of armature / Outros tipos armadura

p.72

Dimensioni / Dimension / Dimensões

Codice d'ordine / Order code / Código para pedido

TAGLIA SIZE TAMANHO	A	B	C (H8)	D (H9)	E	F	f	G	H	I	L	M	N	O	P	R	S
FM39	18.35	16	11	39	31	19.5	4	-	33.5	1.5	4 x 3.4	2 x 5	2 x 2.1	0.8	12.5	2 x 3.7	0.1
FM45	21.55	19	13	45	34	23	4.5	-	38	2	4 x 3.4	3 x 6	3 x 2.6	1.2	15	3 x 4.5	0.15
FM54	25.4	22.3	19	54	43	30	5.5	-	47	2	4 x 3.4	3 x 6.5	3 x 3.1	1.6	21	3 x 5	0.15
FM65	26.7	23.5	26	65	54	38	5.5	-	58	2	4 x 3.4	3 x 6.5	3 x 3.1	1.6	29	3 x 5	0.2
FM80	22	18	35	80	63	46	-	3.5	72	2	4 x 4.5	3 x 6.3	3 x 3.1	1.4	34.5	3 x 5.5	0.2
FM100	24.5	20	42	100	80	60	-	4.3	90	2.5	4 x 5.5	3 x 8	3 x 4.1	1.7	41.7	3 x 7	0.2
FM125	27.9	22	52	125	100	76	-	5	112	3	4 x 6.6	3 x 10.5	3 x 5.1	2.1	51.5	3 x 9	0.2
FM150	31	24	62	150	125	95	-	5.5	137	3.5	4 x 6.6	3 x 12	3 x 6.1	2.5	61.5	3 x 10	0.3
FM190	35	26	80	190	160	120	-	6	175	4	4 x 9	3 x 15	3 x 8.2	3	79.5	3 x 13	0.3
FM230	41.4	30	100	230	200	158	-	7	215	5	4 x 9	3 x 18	3 x 10.2	4	99.5	3 x 16	0.5

TAGLIA SIZE TAMANHO	TIPO ANCORA TYPE ARMATURE TIPO ARMADURA
FM100	.02
FM39 ... FM230	01 02 03 04