

Dipl.-Ing. Herwarth Reich GmbH

ARCUSAFLEX®-VSK

Highly torsionally
flexible coupling
for drive shafts

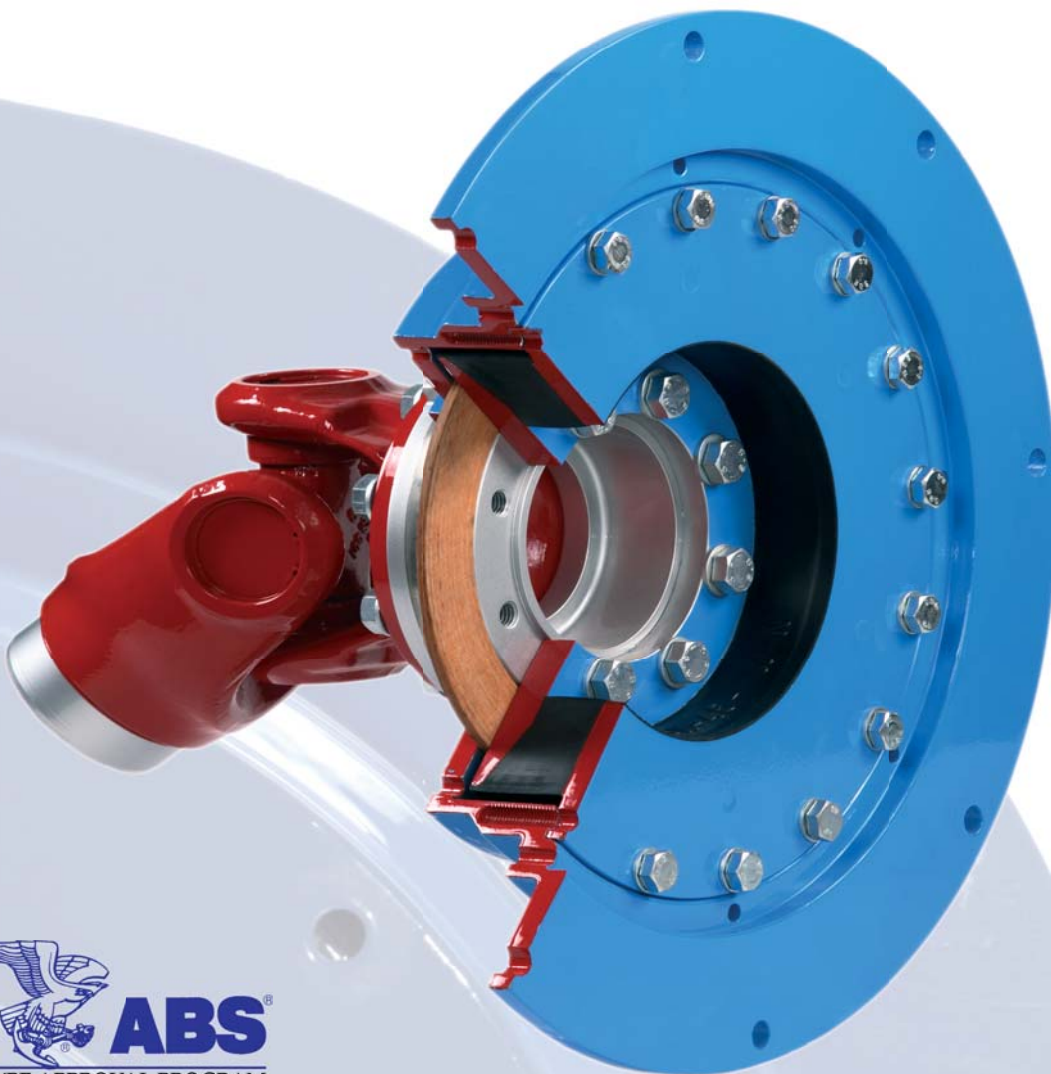

Your drive is our strength. Your strength is our drive.



Contents

	Page
General technical description	3
Design and function / Materials	4
Standard types	5
Special types	6
Technical data / Coupling size selection	7
Dimensional details for ARCUSAFLEX®-VSK flange couplings Type AC-VSK...F2 for cardan shafts with metric DIN flanges	8
Dimensional details for ARCUSAFLEX®-VSK flange couplings Type AC-VSK...F2 for SPICER cardan shafts	10
Dimensional details for ARCUSAFLEX®-VSK flange couplings Type AC-VSK...F2 for MECHANICS cardan shafts	12
Dimensional details for ARCUSAFLEX®-VSK flange couplings Type AC-VSK...F2.CV for constant velocity shafts	14
Dimensional details for ARCUSAFLEX®-VSK double flange couplings Type AC-VSK...F1	16
Dimensional details for ARCUSAFLEX®-VSK shaft couplings Type AC-VSK...F1W	17
Assembly and maintenance instructions	18
General maintenance and wear inspections	19

Conversion table

1 [°F]	9/5 °C + 32	1 [°C]	5/9 (°F - 32)
1 [oz] (avdp)	0.454 [kg]	1 [kg]	2.205 [oz] (avdp)
1 [in]	25.4 [mm]	1 [mm]	0.039 [in]
1 [lb-in]	0.113 [Nm]	1 [Nm]	8.851 [lb-in]
1 [lb-in/rad]	0.113 [Nm/rad]	1 [Nm/rad]	8.851 [lb-in/rad]
1 [lb-in ²]	0.000292 [kgm ²]	1 [kgm ²]	3417.17 [lb-in ²]
1 psi	0.069 bar	1 bar	14504 psi

Edition April 2011

This ARCUSAFLEX®-VSK edition supercedes all previous catalogues of this coupling type. All dimensions in millimeters and inches. We reserve the right to change dimensions and / or design details without prior notice.

Proprietary notice pursuant to ISO 16016 to be observed:

The reproduction, distribution and utilization of this document as well as the communication of its contents to others without explicit authorization is prohibited. Offenders will be held liable for the payment of damages. All rights reserved in the event of the grant of a patent, utility model or design.

© **REICH-KUPPLUNGEN**

General technical description

Cardan shafts are used in a drive train when a large shaft displacement or an extended distance between the drive and the driven components must be compensated. Depending on the arrangement of the drive train components, a nonuniform motion of the speed may result, and since cardan shafts exhibit some torsional flexibility, the mass of the prime mover and driven machine may induce a resonant system.

If the prime mover is an internal combustion engine, a highly flexible AC-VSK coupling is required to protect the drive train from dynamic overload. Highly flexible AC-VSK couplings are capable of shifting resonant ranges below the lowest operating speed and of reducing resonance-induced vibratory torques under reversed stresses to tolerable levels.

The highly flexible AC-VSK coupling is mounted on the engine flywheel, ahead of the drive train with drive shaft. The AC-VSK coupling contains its own axial and radial bearing to support the weight of the drive shaft and its reaction forces.

Coupling Sizes

The AC-VSK coupling series is available in nine standard sizes covering a torque range from 3,450 to 177,000 lb-in (390 to 20,000 Nm). REICH-KUPPLUNGEN has an extensive program of couplings to cover nearly every drive configuration. Customized solutions can be developed and manufactured even in small batches or as prototypes. Calculation programs are available for coupling selection and sizing.

- Please challenge us!

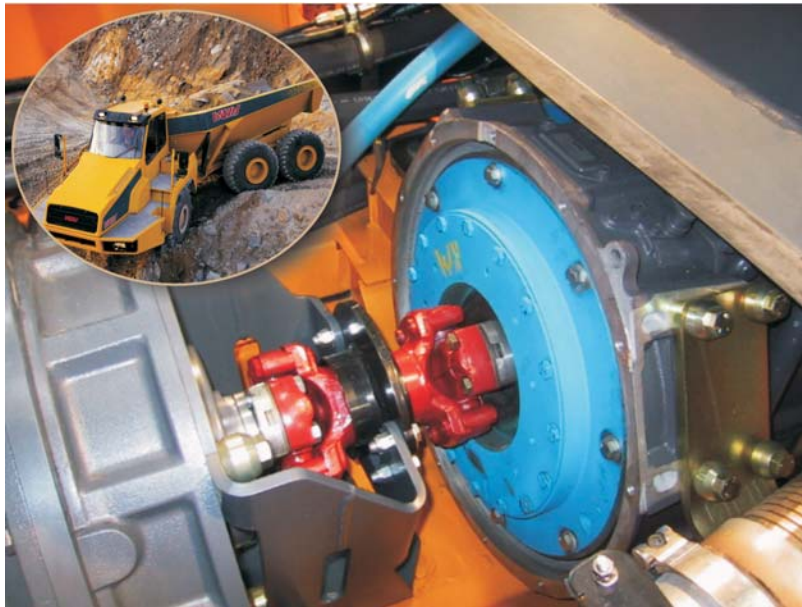

Application of the highly flexible ARCUSAFLEX®-VSK couplings

For use with combustion engines in conjunction with drive shafts for splitter gearboxes, torque converters, ship gearboxes, control gears and pump drives, for example in drives of construction equipment, excavators, cranes, marine propulsion, locomotives, pump installations and dump trucks.

Advantages of the ARCUSAFLEX®-VSK couplings:

- Linear torsional deflection characteristic
- Elements available in different torsional stiffnesses
- Enhanced damping capacity through frictional damping
- Maintenance-free coupling bearings
- Radial bearing close to the cardan joint
- A variety of designs for different cardan shaft configurations
- Many types with SAE connection dimensions or as specified
- Compact construction, the highly flexible element being protected by the housing
- Fail-safe device visible from the outside for ease of inspection

Design and function / Materials

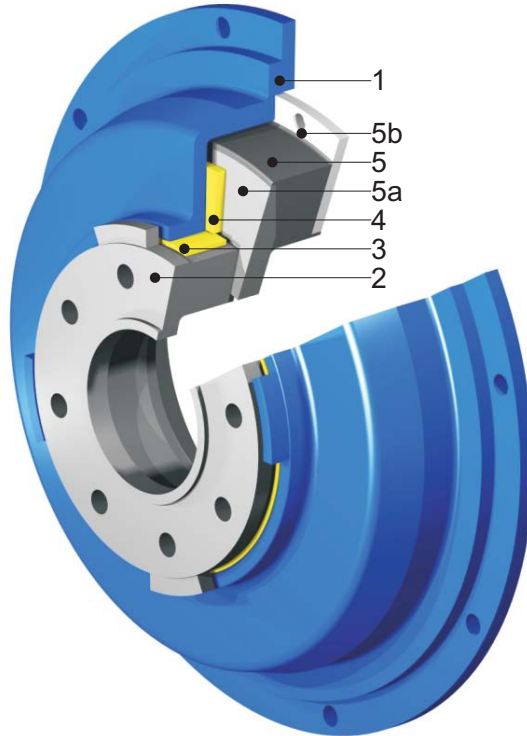

Coupling shown with fail-safe device

Item	Designation	Material
1	Coupling flange	Standard design spheroidal cast iron (GGG 40)
2	Drive shaft connection flange	Steel (yield strength min. 360 N/mm ² - 52,2 psi)
3	Radial bearing	Metal or plastic (maintenance-free)
4	Thrust bearing	Composite material (maintenance-free)
5	Flexible element	Rubber according to technical details
5a, 5b	Element discs	Steel

The highly flexible ARCUSAFLEX®-VSK couplings of the type AC-VSK ... F2 are specially designed for fitting to flywheels of internal combustion engines. The coupling flanges ① of the standard design, therefore, match engine flywheels with SAE connecting dimensions.

The highly flexible coupling element ⑤, is made of rubber bonded to steel discs and is mounted with an axial preload acting on the thrust bearing ④. The output flange ②, used to connect the cardan shaft is precisely located by means of the thrust bearing ④ and the radial bearing ③ ensuring excellent concentricity.

The dynamic performance of the coupling is improved by the pre-loaded rubber element and stabilizing effect of the support bearings providing enhanced damping capacity due to additional frictional damping.

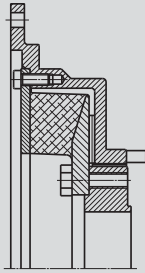

Type AC-VSK...F2

To connect an engine flywheel to a cardan shaft with metric DIN flange
 $T_{KN} = 3,450 - 177,000 \text{ lb-in}$ ($T_{KN} = 390 - 20\,000 \text{ Nm}$)

Technical data Page 7

Dimensions Page 8

Available with or without fail-safe device

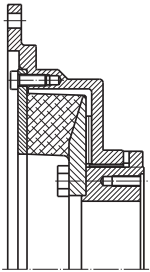

Type AC-VSK...F2

To connect an engine flywheel to a **SPICER** cardan shaft

$T_{KN} = 3,450 - 177,000 \text{ lb-in}$ ($T_{KN} = 390 - 20\,000 \text{ Nm}$)

Technical data Page 7

Dimensions Page 10

Available with or without fail-safe device

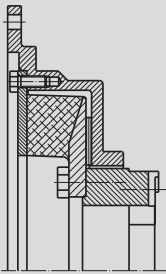

Type AC-VSK...F2

To connect an engine flywheel to a **MECHANICS** cardan shaft

$T_{KN} = 3,450 - 177,000 \text{ lb-in}$ ($T_{KN} = 390 - 20\,000 \text{ Nm}$)

Technical data Page 7

Dimensions Page 12

Available with or without fail-safe device

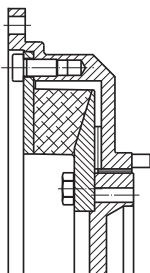

Type AC-VSK...F2.CV

To connect an engine flywheel to a constant velocity shaft

$T_{KN} = 3,450 - 177,000 \text{ lb-in}$ ($T_{KN} = 390 - 20\,000 \text{ Nm}$)

Technical data Page 7

Dimensions Page 14

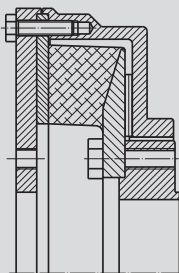

Type AC-VSK...F1

To connect a flange with cardan shaft connection to a cardan shaft

$T_{KN} = 3,450 - 177,000 \text{ lb-in}$ ($T_{KN} = 390 - 20\,000 \text{ Nm}$)

Technical data Page 7

Dimensions Page 16

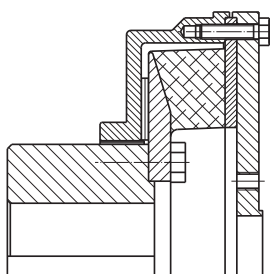

Type AC-VSK...F1W

To connect a shaft to a cardan shaft

$T_{KN} = 3,450 - 177,000 \text{ lb-in}$ ($T_{KN} = 390 - 20\,000 \text{ Nm}$)

Technical data Page 7

Dimensions Page 17

Special types

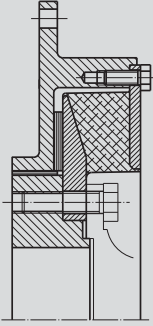

Short type AC-VSK...F2

Narrow width to connect an engine flywheel to a cardan shaft

$T_{KN} = 3,450 - 44,250 \text{ lb-in}$ ($T_{KN} = 390 - 20\,000 \text{ Nm}$)

Technical data Page 7

Dimension table available

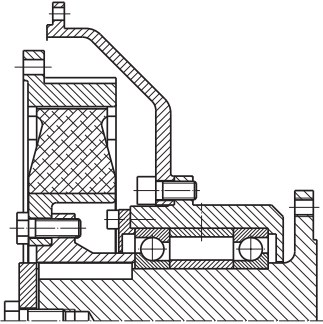

Type AC...F2 FG-GL Flange housing

Highly flexible ARCUSAFLEX® flange coupling with integral shaft support to connect a cardan shaft having a large deflection angle, also available with integrated clutch.

A separate shaft bearing support attached to the engine housing keeps the crankshaft of the engine free from the additional stresses arising from cardan shaft fitment.

$T_{KN} = 4,425 - 177,000 \text{ lb-in}$ ($T_{KN} = 500 - 20\,000 \text{ Nm}$)

Technical data and dimension tables available on request

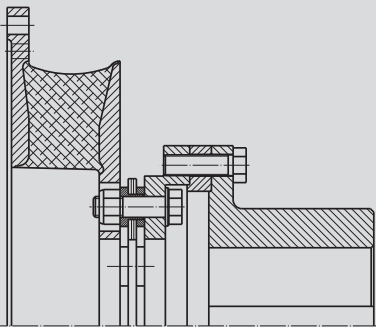

Type FD-VSK

Highly flexible coupling element AC-VSK in combination with a FlexDur disc pack.

For compensating large radial shaft displacements (e.g. in the case of flexibly mounted internal combustion engines). Axial compensation is ensured by the FlexDur disc pack.

For torques up to $247,800 \text{ lb-in}$ ($28\,000 \text{ Nm}$)

Technical data and dimensions available on request

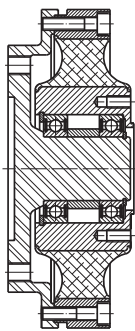

Type TOK

Highly flexible torsionally optimized coupling used in connection with a cardan shaft, constant velocity shaft, flange or splined shaft profile

$T_{KN} = 885 - 380,550 \text{ lb-in}$ ($T_{KN} = 100 - 43\,000 \text{ Nm}$)

Catalogue available on request

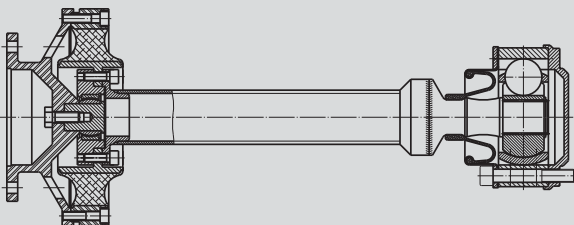

Special type TOK for test benches

Highly flexible torsionally optimized coupling for engine test benches

Available designs:

Integrated bearing with cardan shafts

Integrated bearing with constant velocity shafts

Double element coupling with / without telescopic unit

$T_{KN} = 885 - 265,500 \text{ lb-in}$ ($T_{KN} = 100 - 30\,000 \text{ Nm}$)

$n_{max} = 10\,000 \text{ rpm}$

Size	Element version	Nominal torque T_{KN}		Maximum torque T_{Kmax}		Cont. vibratory torque ²⁾ T_{KW} (10 Hz)		Permissible power loss P_{KV} (30°C)	Dynamic torsional stiffness C_T dyn		Relative damping ¹⁾ [-]	Maximum speed n_{max} [rpm]
		[Nm]	[lb-in]	[Nm]	[lb-in]	[Nm]	[lb-in]		[Nm/rad]	[lb-in/rad]		
AC-VSK 15	EN	390	3452	1170	10355	140	1239	120	2400	21242	1.00	4500 (8") 4000 (10")
	WN	450	3983	1350	11949				2900	25667	1.25	
	NN	560	4956	1680	14869				4500	39828	1.40	
AC-VSK 25	EN	710	6284	2130	18852	250	2213	190	4500	39828	1.00	4000 (10") 3500 (11.5")
	WN	820	7258	2440	21596				5200	46024	1.25	
	NN	1000	8851	3000	26552				8000	70806	1.40	
AC-VSK 35	EN	1100	9736	3300	29207	400	3540	220	7800	69036	1.00	3600 (10") 3500 (11.5") 3000 (14")
	WN	1250	11063	3750	33190				9500	84082	1.25	
	NN	1600	14161	4800	42484				14000	123910	1.40	
AC-VSK 45	EN	1400	12391	4200	37173	525	4647	240	9000	79657	1.00	3500 (11.5") 3000 (14")
	WN	1600	14161	4800	42484				11000	97358	1.25	
	NN	2100	18587	6300	55760				17000	150463	1.40	
AC-VSK 50	EN	2000	17701	6000	53104	750	6638	280	14000	123910	1.00	3000 (14") 2300 (18")
	WN	2300	20357	6900	61070				18000	159313	1.25	
	NN	3000	26552	9000	79657				24000	212418	1.40	
AC-VSK 55	EN	3500	30978	10500	92933	1250	11063	335	24000	212418	1.00	2600 (14") 2300 (18")
	WN	4000	35403	12000	106209				30000	265522	1.25	
	NN	5000	44254	15000	132761				45000	398284	1.40	
AC-VSK 60	EN	4400	38943	13200	116830	1550	13719	375	35000	309776	1.00	2500 (14") 2300 (18")
	WN	5000	44254	15000	132761				42000	371731	1.25	
	NN	6200	54875	18600	164624				65000	575298	1.40	
AC-VSK 70	EN	7000	61955	21000	185866	2500	22127	445	50000	442537	1.00	2300 (18") 2100 (21")
	WN	8000	70806	24000	212418				62000	548746	1.25	
	NN	10000	88507	30000	265522				93000	823119	1.40	
AC-VSK 85	EN	14000	123910	42000	371731	5000	44254	650	96000	849672	1.00	2100 (21")
	WN	16000	141612	48000	424836				120000	1062089	1.25	
	NN	20000	177015	60000	531045				185000	1637388	1.40	

Shore hardness of the rubber element version: EN = 50 °Shore A; WN = 55 °Shore A; NN = 65 °Shore A

1) The relative damping relates only to the elastomer. The frictional damping of the bearings has to be considered separately, depending on the type of operation.

2) Continuous vibratory torque under reversing stresses $\pm T_{KW}$ at $f = 10$ Hz, for other frequencies f_x apply $T_{KW} \cdot \sqrt{\frac{10}{f_x}}$

Coupling size selection

The selected coupling for internal combustion engine drives should be verified by a torsional vibration analysis which we will provide on request. A preliminary selection of the coupling can, however, be made based on the continuous engine power being transmitted.

Calculation of the **nominal drive torque** T_{AN} :

The **nominal torque capacity** T_{KN} of the coupling should be at least equal to the maximum engine torque T_{AN} at any operating temperature.

The **temperature factor** S_t allows for the decreasing load capacity of the coupling when affected by elevated ambient temperatures close to the coupling.

The torsional vibration analysis to verify the coupling selection should confirm that the permissible continuous vibratory torque under reversing stresses T_{KW} is at least equal to the highest vibratory torque under reversing stresses T_W encountered throughout the operating speed range whilst taking into account the temperature and frequency.

The **frequency factor** S_f allows for the frequency dependence of the permissible continuous vibratory torque under reversing stresses T_{KW} (10 Hz) when operating with a different frequency f_x .

$$T_{AN} [\text{lb-in}] = 63,000 \cdot \frac{P [\text{HP}]}{n [\text{rpm}]}$$

$$T_{KN} \geq T_{AN} \cdot S_t$$

Temp.	140 °F 60 °C	158 °F 70 °C	176 °F 80 °C	>176 °F >80 °C
S_t	1.25	1.4	1.6	on request

$$T_{KW} (10 \text{ Hz}) \geq T_W \cdot S_t \cdot S_f$$

$$S_f = \sqrt{\frac{f_x}{10}}$$

Type AC-VSK...F2 for cardan shafts with metric DIN flange

Engine flywheels with SAE connecting dimensions acc. to J620

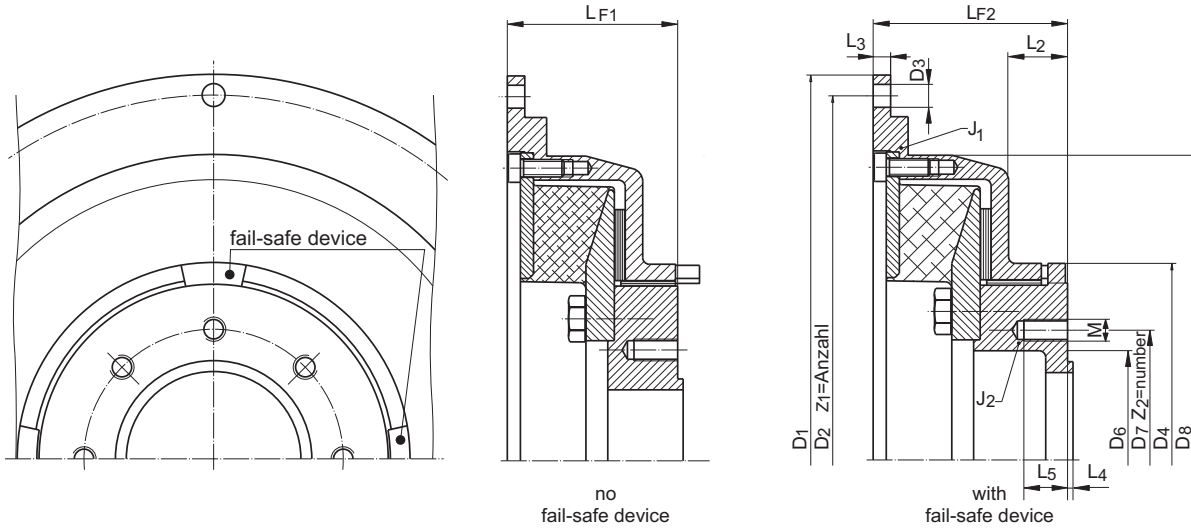

AC-VSK coupling size	Flywheel connection dimensions						Cardan shaft connecting dimensions										J ₁ [kgm ²]	J ₂ ⁵⁾ [kgm ²]	Total ⁵⁾ weight [kg]							
	SAE size	D ₁ [mm]	D ₂ [mm]	D ₃ [mm]	Z ₁	D ₄ [mm]	D ₈ [mm]	L ₂ [mm]	L ₃ [mm]	L _{F1} [mm]	L _{F2} [mm]	Flange Ø [mm]	D ₆ h ₆	D ₇ [mm]	Z ₂ x M ²⁾	L ₄ [mm]				L ₅ [mm]						
- 15. ¹⁾ .F2	8	263.5	244.5	10.5	6	140	215	18	8	57	68	100	57	84.0	6 x M8	2.0	16	0.055	0.010	8.9						
	10	314.3	295.3	10.5	8							120	75	101.5	8 x M10			0.084		10.3						
- 25. ¹⁾ .F2	10	314.3	295.3	10.5	8	144	260	22	10	74	85	120	75	101.5	8 x M10	2.0	20	0.148	0.023	15.8						
	11.5	352.4	333.4	10.5														0.188		17.2						
- 35. ¹⁾ .F2	10	314.3	295.3	10.5	8	180	279	28	8	78	90	120	75	101.5	8 x M10	2.0	20	0.144	0.052	17.0						
	11.5	352.4	333.4	10.5														8		150	90	130.0	8 x M12	2.5	0.177	18.2
	14	466.7	438.2	13.0														8		0.362	22.5					
- 45. ¹⁾ .F2	11.5	352.4	333.4	10.5	8	180	314	25	26	89	100	150	90	130.0	8 x M12	2.5	20	0.281	0.066	23.9						
	14	466.7	438.2	13.0														10		0.517	29.5					
- 50. ¹⁾ .F2	14	466.7	438.2	13.0	8	210	352	36	12	103	120	150	90	130.0	8 x M12	2.5	25	0.668	0.123	37.2						
	18	571.5	542.9	17.0								180	110	155.5	8 x M14	3.0	30	1.180		44.7						
- 55. ¹⁾ .F2	14	466.7	438.2	13.0	8	285	417	35	28	115	130	180	110	155.5	8 x M14	3.0	25	1.087	0.380	55.0						
	18	571.5	542.9	17.0								6	225	140	196.0			8 x M16		4.0	30	1.754	0.378	64.4		
																						250	140	218.0	8 x M18	4.0
- 60. ¹⁾ .F2	14	466.7	438.2	13.0	8	300	424	47	25 ³⁾	122	137	225	140	196.0	8 x M16	4.0	45	1.100	0.464	60.5						
	18	571.5	542.9	17.0								6	15	133	148			250		140	218.0	8 x M18	1.878	72.2		
- 70. ¹⁾ .F2	18	571.5	542.9	17.0	6	348	510	46	15	139	160	250	140	218.0	8 x M18	4.0	30	2.681	1.080	105.6						
	21	673.1	641.4	17.0								12	285	175	245.0	8 x M20	5.0	35		3.747	1.073	116.5				
- 85. ¹⁾ .F2	21	673.1	641.4	17.0	12	440	610	66	35 ⁴⁾	160	181	285	175	245.0	8 x M20	5.0	35	6.857	2.231	155.2						
												315	175	280.0	8 x M22	5.0	35									

- 1) For the element version see "Technical data" on page 7 • 2) Alternative connection threads on request • 3) Centering depth 9 mm
 4) Centering depth 14 mm • 5) Values without fail-safe device

Ordering example: Coupling designation: AC-VSK 50.WN.F2.14.150-M12 DS

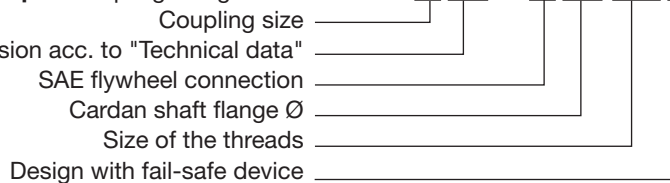

Type AC-VSK...F2 for cardan shafts with metric DIN flange

Engine flywheels with SAE connecting dimensions acc. to J620

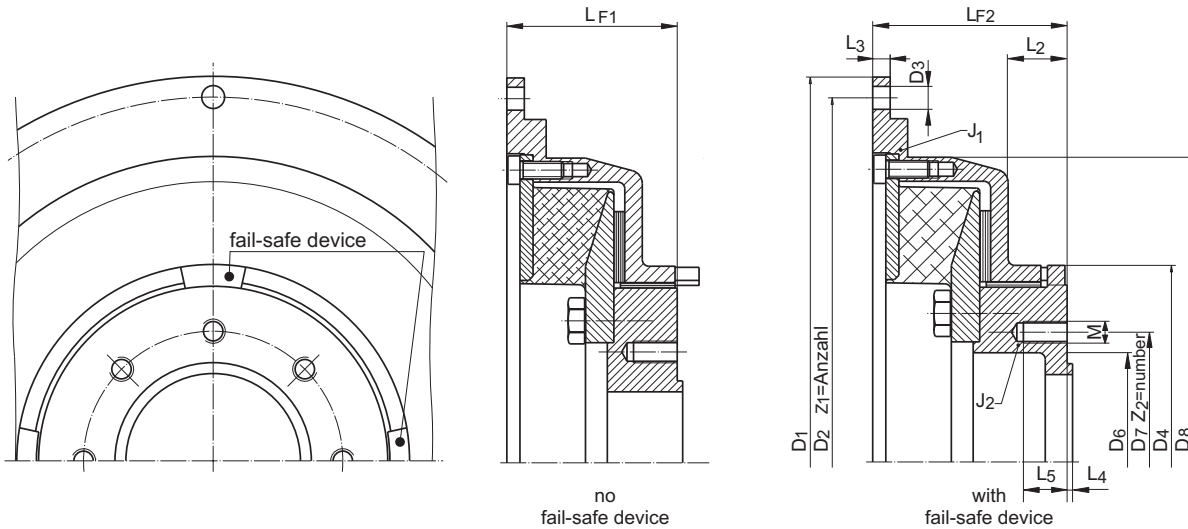

AC-VSK coupling size	Flywheel connection dimensions						Cardan shaft connecting dimensions										J ₁ [lb-in ²]	J ₂ ⁵⁾ [lb-in ²]	Total ⁵⁾ weight [lb]			
	SAE size	D ₁ [in]	D ₂ [in]	D ₃ [in]	Z ₁	D ₄ [in]	D ₈ [in]	L ₂ [in]	L ₃ [in]	L _{F1} [in]	L _{F2} [in]	Flange Ø	D ₆ h ₆	D ₇ [in]	Z ₂ x M ²⁾	L ₄ [in]				L ₅ [in]		
- 15. ¹⁾ .F2	8	10.374	9.626	0.41	6	5.51	8.46	0.71	0.31	2.24	2.68	3.94	2.244	3.307	6 x M8	0.08	0.63	187.9	34.2	19.6		
	10	12.374	11.626	0.41	8							4.72	2.953	3.996	8 x M10			287.0		22.7		
- 25. ¹⁾ .F2	10	11.626	11.626	0.41	8	5.67	10.24	0.87	0.39	2.91	3.35	4.72	2.953	3.996	8 x M10	0.08	0.79	505.7	78.6	34.9		
	11.5	13.874	13.126	0.41								642.4	38.0									
- 35. ¹⁾ .F2	10	12.374	11.626	0.41	8	7.09	10.98	1.10	0.31	3.07	3.54	4.72	2.953	3.996	8 x M10	0.08	0.79	492.1	177.7	37.5		
	11.5	13.874	13.126	0.41								5.91	3.543	5.118	8 x M12			604.8		40.2		
	14	13.874	17.252	0.51								0.31	1237.0	49.7								
- 45. ¹⁾ .F2	11.5	13.874	13.126	0.41	8	7.09	12.36	0.98	1.02	3.50	3.94	5.91	3.543	5.118	8 x M12	0.10	0.79	960.2	225.5	52.7		
	14	18.374	17.252	0.51								0.39	1766.7	65.1								
- 50. ¹⁾ .F2	14	18.374	17.252	13.0	8	8.27	13.86	1.42	0.47	4.06	4.72	5.91	3.543	5.118	8 x M12	0.10	0.98	2282.7	420.3	82.1		
	18	22.500	21.374	0.67								7.09	4.331	6.122	8 x M14			4032.3		98.7		
- 55. ¹⁾ .F2	14	18.374	17.252	0.51	8	11.22	16.42	1.38	1.10	4.53	5.12	7.09	4.331	6.122	8 x M14	0.12	0.98	3714.5	1298.5	121.4		
	18	22.500	21.374	0.67								6	8.86	5.512	7.717			8 x M16		5993.7	1291.7	142.1
- 60. ¹⁾ .F2	14	18.374	17.252	0.51	8	11.81	16.69	1.85 ³⁾	0.98	4.80	5.39	8.86	5.512	7.717	8 x M16	0.16	1.77	3758.9	1585.6	133.5		
	18	22.500	21.374	0.67								6	0.59	5.24	5.83			9.84		5.512	8.583	8 x M18
- 70. ¹⁾ .F2	18	22.500	21.374	0.67	6	13.7	20.08	1.81	0.59	5.47	6.30	9.84	5.512	8.583	8 x M18	0.16	1.18	9161.4	3690.5	233.1		
	21	26.500	25.252	0.67								12	11.22	6.890	9.646			8 x M20		12804.1	3666.6	257.1
- 85. ¹⁾ .F2	21	26.500	25.252	0.67	12	17.32	24.02	2.60 ⁴⁾	1.38	6.30	7.13	11.22	6.890	9.646	8 x M20	0.20	1.38	23431.5	7623.7	342.5		
												12.40	6.890	11.024	8 x M22						0.20	1.38

1) For the element version see "Technical data" on page 7 • 2) Alternative connection threads on request • 3) Centering depth 0.35 in.
 4) Centering depth 0.55 in. • 5) Values without fail-safe device

Ordering example: Coupling designation: AC-VSK 50.WN.F2.14.150-M12 DS

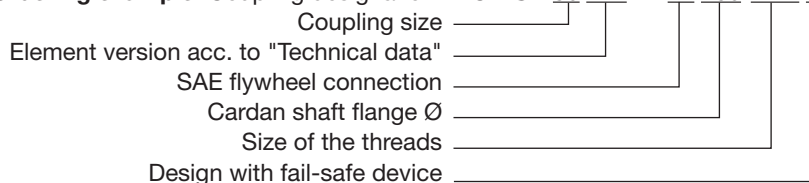

Type AC-VSK...F2 for SPICER cardan shafts

Engine flywheels with SAE connecting dimensions acc. to J620

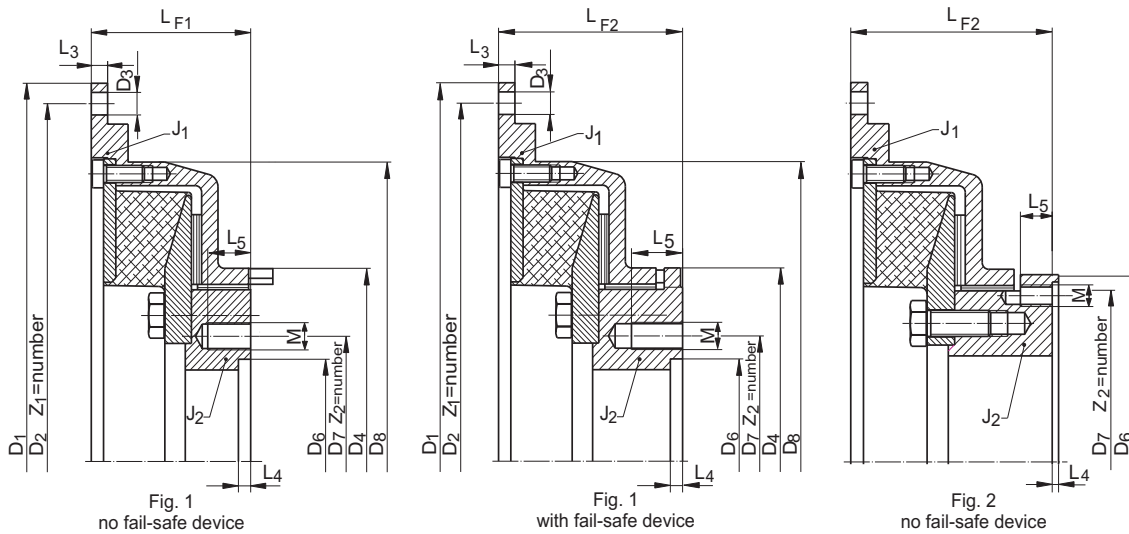

AC-VSK coupling size	Flywheel connection dimensions					SPICER cardan shaft connecting dimensions											J ₁ [kgm ²]	J ₂ ⁽⁶⁾ [kgm ²]	Total ⁽⁶⁾ weight [kg]	
	SAE size	D ₁ [mm]	D ₂ [mm]	D ₃ [mm]	Z ₁	D ₄ [mm]	D ₈ [mm]	L ₃ [mm]	L _{F1} [mm]	L _{F2} [mm]	size	Fig.	D ₆ H ₆	D ₇ [mm]	Z ₂ x M ⁽²⁾	L ₄ [mm]				L ₅ [mm]
-15. ¹⁾ F2	8	263.5	244.5	10.5	6	140	215	8	57	68	1280/1310	1	60.33	79.38	4 x 3/8" - 24	5	20	0.055	0.010	8.9
	10	314.3	295.3	10.5	8						1350/1410				69.85			95.25		4 x 7/16" - 20
-25. ¹⁾ F2	10	314.3	295.3	10.5	8	144	260	10	74	85	1280/1310	1	60.33	79.38	4 x 3/8" - 24	5	20	0.148	0.023	15.8
	11.5	352.4	333.4	10.5							1350/1410				69.85			95.25		4 x 7/16" - 20
-35. ¹⁾ F2	10	314.3	295.3	10.5	8	180	279	16	78	90	1480/1550	1	95.25	120.65	4 x 1/2" - 20	6	25	0.144	0.052	17.0
	11.5	352.4	333.4	10.5							1610 ⁽³⁾				2			168.28		155.58
	14	466.7	438.2	13.0				8	95	-	1610 ⁽³⁾	2	168.28	155.58	8 x 3/8" - 24	2	15	0.362	0.058	23.5
-45. ¹⁾ F2	11.5	352.4	333.4	10.5	8	180	314	26	89	100	1480/1550	1	95.25	120.65	4 x 1/2" - 20	6	25	0.281	0.066	23.9
	14	466.7	438.2	13.0				10	105	-	1610 ⁽³⁾				2			168.28		155.58
-50. ¹⁾ F2	14	466.7	438.2	13.0	8	210	352	12	100	117	1610	2	168.28	155.58	8 x 3/8" - 24	3	17	0.668	0.123	37.2
									125	-	1710 ⁽³⁾				8 x 3/8" - 24			0.138		39.2
	18	571.5	542.9	17.0	6	1760/1810 ⁽³⁾	196.85	184.15	12 x 7/16" - 20	1.180	46.7									
-55. ¹⁾ F2	14	466.7	438.2	13.0	8	285	417	28	112	127	1710	2	196.85	184.15	8 x 3/8" - 24	3	30	1.087	0.380	55.0
									115	130	1880/1910				1			177.80		209.55
	18	571.5	542.9	17.0	6	115	130	1880/1910	1	177.80	209.55	8 x 5/8" - 18	7	1.754	64.4					
-60. ¹⁾ F2	14	466.7	438.2	13.0	8	300	424	25 ⁽⁴⁾	119	134	1760/1810	2	196.85	184.15	12 x 7/16" - 20	3	30	1.100	0.509	64.9
	18	571.5	542.9	17.0	6			15	133	148	1880/1910				1			177.80		209.55
-70. ¹⁾ F2	18	571.5	542.9	17.0	6	348	510	15	139	160	1880/1910	1	177.80	209.55	8 x 5/8" - 18	7	35	2.681	1.080	105.6
	21	673.1	641.4	17.0	12						1950				209.55			249.30		12 x 3/4" - 16
-85. ¹⁾ F2	21	673.1	641.4	17.0	12	440	610	35 ⁽⁵⁾	160	181	1880/1910	1	177.80	209.55	8 x 5/8" - 18	7	35	6.857	2.229	157.8
											1950				209.55			249.30		12 x 3/4" - 16

1) For the element version see "Technical Data" on page 7 • 2) Alternative connection threads on request

3) This version not available with fail-safe device • 4) Centering depth 9 mm • 5) Centering depth 14 mm • 6) Values without fail-safe device

Ordering example: Coupling designation: **AC-VSK 50.WN.F2.14.1610.DS**

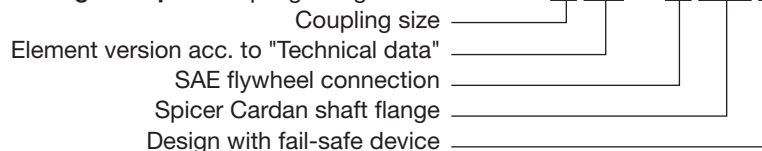

Type AC-VSK...F2 for SPICER cardan shafts
 Engine flywheels with SAE connecting dimensions acc. to J620

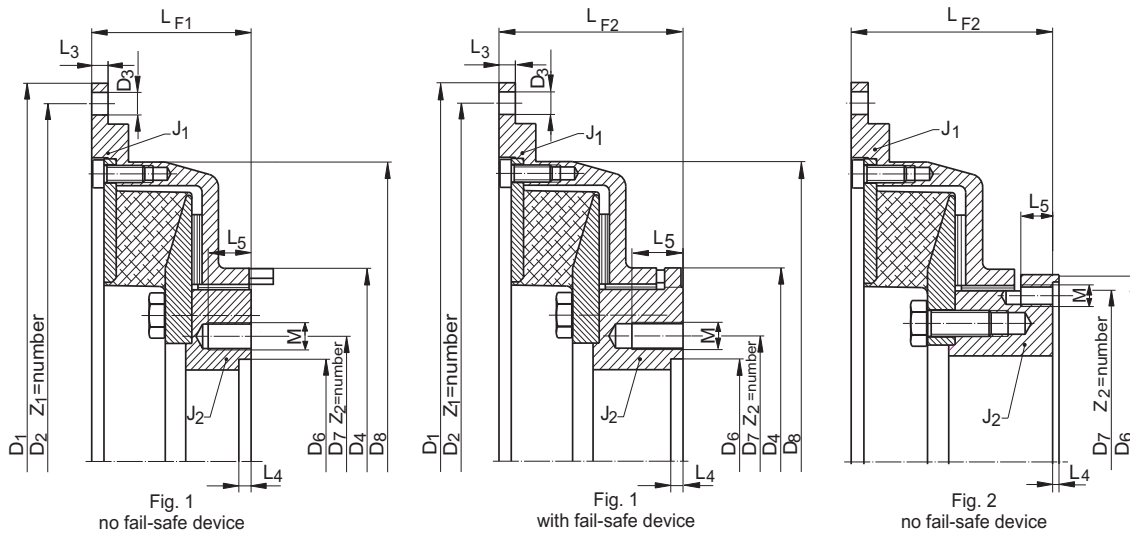

AC-VSK coupling size	Flywheel connection dimensions						SPICER cardan shaft connecting dimensions										Total ⁽⁶⁾ weight [lb]			
	SAE size	D ₁ [in]	D ₂ [in]	D ₃ [in]	Z ₁	D ₄ [in]	D ₈ [in]	L ₃ [in]	L _{F1} [in]	L _{F2} [in]	size	Fig.	D ₆ H ₆ [in]	D ₇ [in]	Z ₂ x M ⁽²⁾	L ₄ [in]		L ₅ [in]	J ₁ [lb-in ²]	J ₂ ⁽⁶⁾ [lb-in ²]
- 15. ¹⁾ .F2	8	10.374	9.626	0.41	6	5.51	8.46	0.31	2.24	2.68	1280/1310	1	2.375	3.125	4 x 3/8"- 24	0.20	0.79	187.9	34.2	19.6
	10	12.374	11.626	0.41	8						1350/1410				2.750					3.750
- 25. ¹⁾ .F2	10	12.374	11.626	0.41	8	5.67	10.24	0.39	2.91	3.35	1280/1310	1	2.375	3.125	4 x 3/8"- 24	0.20	0.79	505.7	78.6	34.9
	11.5	13.874	13.126	0.41							1350/1410				2.750					3.750
- 35. ¹⁾ .F2	10	12.374	11.626	0.41	8	7.09	10.98	0.63	3.07	3.54	1480/1550	1	3.750	4.750	4 x 1/2"- 20	0.24	0.98	492.1	177.7	37.5
	11.5	13.874	13.126	0.41							1610 ³⁾				2					6.625
	14	18.374	17.252	0.51				0.31	3.74	-	1610 ³⁾	2	6.625	6.125	8 x 3/8"- 24	0.08	0.59	1237.0	198.2	51.9
- 45. ¹⁾ .F2	11.5	13.874	13.126	10.5	8	7.09	12.36	1.02	3.50	3.94	1480/1550	1	3.750	4.750	4 x 1/2"- 20	0.24	0.98	960.2	225.5	52.7
	14	18.374	17.252	0.51				0.39	4.13	-	1610 ³⁾				2					6.625
- 50. ¹⁾ .F2	14	18.374	17.252	0.51	8	8.27	13.86	0.47	3.94	4.61	1610	2	6.625	6.125	8 x 3/8"- 24	0.12	0.67	2282.7	420.3	82.1
									4.92	-	1710 ³⁾				7.750					7.250
	18	22.500	21.374	0.67	6	1760/1810 ³⁾	12 x 7/16"- 20	4032.3	103.1											
- 55. ¹⁾ .F2	14	18.374	17.252	0.51	8	11.22	16.42	1.10	4.41	5.00	1710	2	7.750	7.250	8 x 3/8"- 24	0.12	1.18	3714.5	1298.5	121.4
									4.53	5.12	1880/1910				1					7.000
	18	22.500	21.374	0.67	6	0.98 ⁴⁾	4.69	5.28	1760/1810	2	7.750	7.250	12 x 7/16"- 20	0.12	1.18	3758.9	1739.3	143.2		
- 60. ¹⁾ .F2	18	22.500	21.374	0.67	6	11.81	16.69	0.59	5.24	5.83	1880/1910	1	7.000	8.250	8 x 5/8"- 18	0.28	1.18	6417.4	1739.3	169.1
	14	18.374	17.252	0.51	8	13.70	20.08	0.59	5.47	6.30	1880/1910	1	7.000	8.250	8 x 5/8"- 18	0.28	1.38	9161.4	3690.5	233.1
21	26.500	25.252	0.67	12	1950	12 x 3/4"- 16	12804.1	3666.6	257.1											
- 85. ¹⁾ .F2	21	26.500	25.252	0.67	12	17.32	24.02	1.38 ⁵⁾	6.30	7.13	1880/1910	1	7.000	8.250	8 x 5/8"- 18	0.28	1.38	23431.5	7616.9	348.3
											1950				12 x 3/4"- 16					

1) For the element version see "Technical Data" on page 7 • 2) Alternative connection threads on request
 3) This version not available with fail-safe device • 4) Centering depth 0.35 in. • 5) Centering depth 0.55 in. • 6) Values without fail-safe device

Ordering example: Coupling designation: **AC-VSK 50.WN.F2.14.1610.DS**

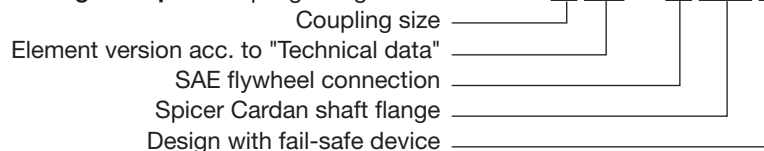

ARCUSAFLEX®-VSK flange couplings

METRIC DIMENSIONS

Type AC-VSK...F2 for MECHANICS cardan shafts

Engine flywheels with SAE connecting dimensions acc. to J620

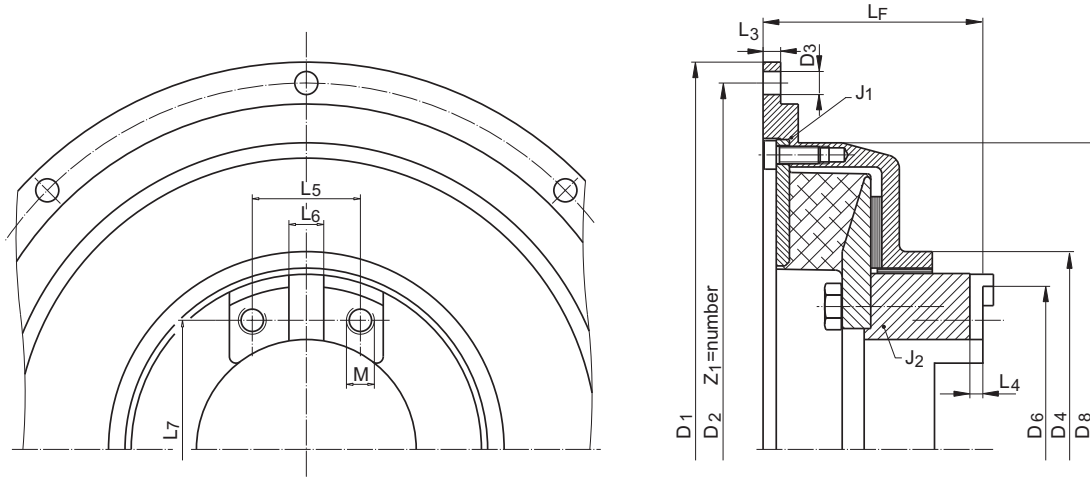

AC-VSK coupling size	Flywheel connection dimensions						MECHANICS cardan shaft connecting dimensions										J ₁ [kgm ²]	J ₂ [kgm ²]	Total weight [kg]		
	SAE size	D ₁ [mm]	D ₂ [mm]	D ₃ [mm]	Z ₁	D ₄ [mm]	D ₈ [mm]	L ₃ [mm]	L _F [mm]	Size	D ₆ H ₇	L ₄ [mm]	L ₅ [mm]	L ₆ [mm]	L ₇ [mm]	M					
- 15. ¹⁾ F2	8	263.5	244.5	10.5	6	140	215	8	83	4C	107.92	3.8	36.5	9.5	87.3	⁵ / ₁₆ "-24	0.055	0.010	8.8		
	10	314.3	295.3	10.5	8					5C	115.06	5.1	42.9	14.26	88.9	³ / ₈ "-24	0.084		10.2		
- 25. ¹⁾ F2	10	314.3	295.3	10.5	8	144	260	10	95	5C	115.06	5.1	42.9	14.26	88.9	³ / ₈ "-24	0.148	0.022	15.3		
	11.5	352.4	333.4	10.5						8	100	6C	140.46	5.1	42.9	14.26	114.3		³ / ₈ "-24	0.362	16.7
- 35. ¹⁾ F2	10	314.3	295.3	10.5	8	180	279	16	100	5C	115.06	5.1	42.9	14.26	88.9	³ / ₈ "-24	0.144	0.048	16.0		
	11.5	352.4	333.4	10.5						8	100	6C	140.46	5.1	42.9	14.26	114.3		³ / ₈ "-24	0.177	17.9
	14	466.7	438.2	13.0						8	100	8C	206.32	6.0	49.2	15.85	174.6		¹ / ₂ "-20	1.087	22.2
- 45. ¹⁾ F2	11.5	352.4	333.4	10.5	8	180	314	26	111	5C	115.06	5.1	42.9	14.26	88.9	³ / ₈ "-24	0.281	0.063	23.5		
	14	466.7	438.2	13.0				10		111	6C	140.46	5.1	42.9	14.26	114.3	³ / ₈ "-24		0.517	29.1	
- 50. ¹⁾ F2	14	466.7	438.2	13.0	8	210	352	12	130	6C	140.46	5.1	42.9	14.26	114.3	³ / ₈ "-24	0.668	0.115	36.2		
										7C	148.39	6.0	49.2	15.85	117.5	¹ / ₂ "-20	1.180		0.116	36.3	
										8.5C	165.08	6.0	71.4	15.85	123.8	¹ / ₂ "-20	1.180		0.114	43.1	
- 55. ¹⁾ F2	14	466.7	438.2	13.0	8	285	417	28	155	8C	206.32	6.0	49.2	15.85	174.6	¹ / ₂ "-20	1.087	0.348	52.1		
										8.5C	165.08	6.0	71.4	15.85	123.8	¹ / ₂ "-20	1.754		0.353	63.1	
										9C	209.52	6.0	71.4	15.85	168.3	¹ / ₂ "-20	1.754		0.356	62.2	
- 60. ¹⁾ F2	14	466.7	438.2	13.0	8	300	424	25 ²⁾	148	8.5C	165.08	6.0	71.4	15.85	123.8	¹ / ₂ "-20	1.100	0.471	62.1		
								15		173	9C	209.52	6.0	71.4	15.85	168.3	¹ / ₂ "-20		1.878	73.8	
- 70. ¹⁾ F2	18	571.5	542.9	17.0	6	348	510	15	170	9C	209.52	6.0	71.4	15.85	168.3	¹ / ₂ "-20	2.681	0.964	99.0		
										21	673.1	641.4	17.0	12	170	10C	212.70		9.5	92.1	25.35
- 85. ¹⁾ F2	21	673.1	641.4	17.0	12	440	610	35 ³⁾	200	12C	289.05	12.5	92.1	25.35	241.3	⁵ / ₈ "-18	6.857	2.305	157.2		
								15C		260.00	12.5	100.0	31.78	200.0	³ / ₄ "-16						
								280		280.00	9.0	92.0	35.00	227.0	M18						

1) For the element version see "Technical data" on page 7 • Version with fail-safe device on request

2) Centering depth 9 mm

3) Centering depth 14 mm

Ordering example: Coupling designation: **AC-VSK 50.WN.F2.14.7C**

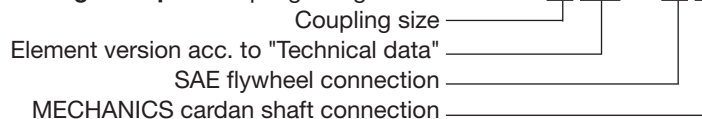

Type AC-VSK...F2 for MECHANICS cardan shafts
 Engine flywheels with SAE connecting dimensions acc. to J620

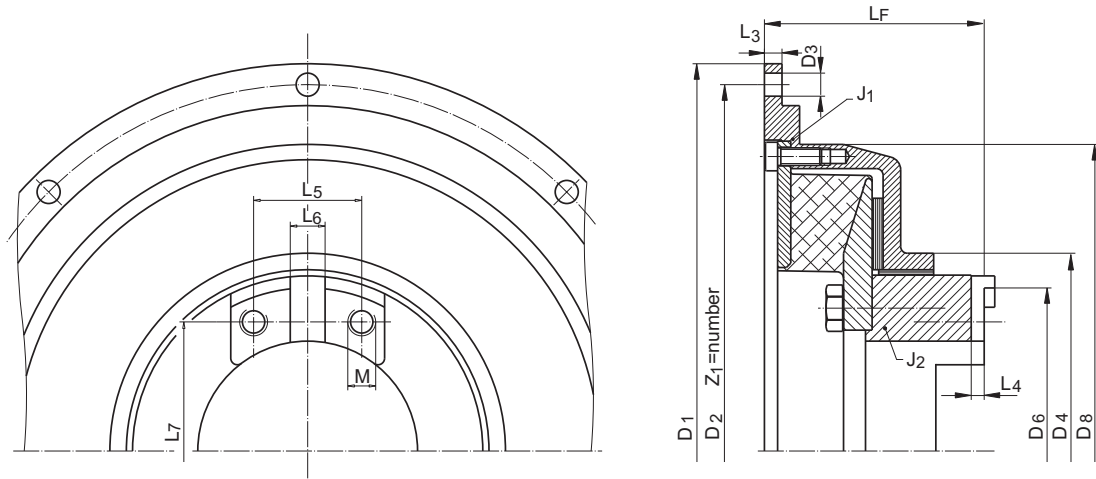

AC-VSK coupling size	Flywheel connection dimensions						MECHANICS cardan shaft connecting dimensions							J ₁ [lb-in ²]	J ₂ [lb-in ²]	Total weight [lb]				
	SAE size	D ₁ [in]	D ₂ [in]	D ₃ [in]	Z ₁	D ₄ [in]	D ₈ [in]	L ₃ [in]	L _F [in]	Size	D ₆ H ₇	L ₄ [in]	L ₅ [in]				L ₆ [in]	L ₇ [in]	M	
- 15. ¹⁾ F2	8	10.374	9.626	0.41	6	5.51	8.46	0.31	3.27	4C	4.249	0.15	1.44	0.37	3.44	⁵ / ₁₆ "-24	187.9	34.2	19.4	
	10	12.374	11.626	0.41	8					5C	4.530	0.20	1.69	0.56	3.50	³ / ₈ "-24	287.0		22.5	
- 25. ¹⁾ F2	10	12.374	11.626	0.41	8	5.67	10.24	0.39	3.74	5C	4.530	0.20	1.69	0.56	3.50	³ / ₈ "-24	505.7	75.2	33.8	
	11.5	13.874	13.126	0.41						6C	5.530	0.20	1.69	0.56	4.50	³ / ₈ "-24	642.4		36.9	
- 35. ¹⁾ F2	10	12.374	11.626	0.41	8	7.09	10.98	0.63	3.94	5C	4.530	0.20	1.69	0.56	3.50	³ / ₈ "-24	492.1	164.0	35.3	
	11.5	13.874	13.126	0.41				0.31		6C	5.530	0.20	1.69	0.56	4.50	³ / ₈ "-24	604.8		39.5	
	14	18.374	17.252	0.51				0.39		4.37	6C	5.530	0.20	1.69	0.56	4.50	³ / ₈ "-24		1237.0	49.0
- 45. ¹⁾ F2	11.5	13.874	13.126	0.41	8	7.09	12.36	1.02	4.37	5C	4.530	0.20	1.69	0.56	3.50	³ / ₈ "-24	960.2	215.3	51.9	
	14	18.374	17.252	0.51				0.39		6C	5.530	0.20	1.69	0.56	4.50	³ / ₈ "-24	1766.7		64.2	
- 50. ¹⁾ F2	14	18.374	17.252	0.51	8	8.27	13.86	0.47	5.12	6C	5.530	0.20	1.69	0.56	4.50	³ / ₈ "-24	2282.7	393.0	79.9	
										7C	5.842	0.24	1.94	0.62	4.63	¹ / ₂ "-20	4032.3	389.6	80.1	
	18	22.500	21.374	0.67						6	8.5C	6.499	0.24	2.81	0.62	4.87	¹ / ₂ "-20	5993.7	1206.3	139.3
- 55. ¹⁾ F2	14	18.374	17.252	0.51	8	11.22	16.42	1.10	6.10	8C	8.123	0.24	1.94	0.62	6.87	¹ / ₂ "-20	3714.5	1189.2	115.0	
	18	22.500	21.374	0.67						6	8.5C	6.499	0.24	2.81	0.62	4.87	¹ / ₂ "-20	5993.7	1206.3	139.3
																				9C
- 60. ¹⁾ F2	14	18.374	17.252	0.51	8	11.81	16.69	0.98 ²⁾	5.83	8.5C	6.499	0.24	2.81	0.62	4.87	¹ / ₂ "-20	3758.9	1609.5	137.1	
	18	22.500	21.374	0.67				6		0.59	6.81	9C	8.249	0.24	2.81	0.62	6.63		¹ / ₂ "-20	6417.4
- 70. ¹⁾ F2	18	22.500	21.374	0.67	6	13.70	20.08	0.59	6.69	9C	8.249	0.24	2.81	0.62	6.63	¹ / ₂ "-20	9161.4	3294.2	218.5	
	21	26.500	25.252	0.67						12	10C	8.374	0.37	3.63	1.00	6.50	⁵ / ₈ "-18		12804.1	242.5
- 85. ¹⁾ F2	21	26.500	25.252	0.67	12	17.32	24.02	1.38 ³⁾	7.87	12C	11.380	0.49	3.63	1.00	9.50	⁵ / ₈ "-18	23431.5	7876.6	346.9	
										15C	10.236	0.49	3.94	1.25	7.87	³ / ₄ "-16				
										280	11.024	0.35	3.62	1.38	8.94	M18				

1) For the element version see "Technical data" on page 7 • Version with fail-safe device on request

2) Centering depth 0.35 in

3) Centering depth 0.55 in.

Ordering example: Coupling designation: **AC-VSK 50.WN.F2.14.7C**

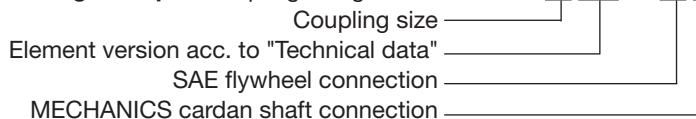

Type AC-VSK...F2.CV for constant velocity shafts

Engine flywheels with SAE connecting dimensions acc. to J620

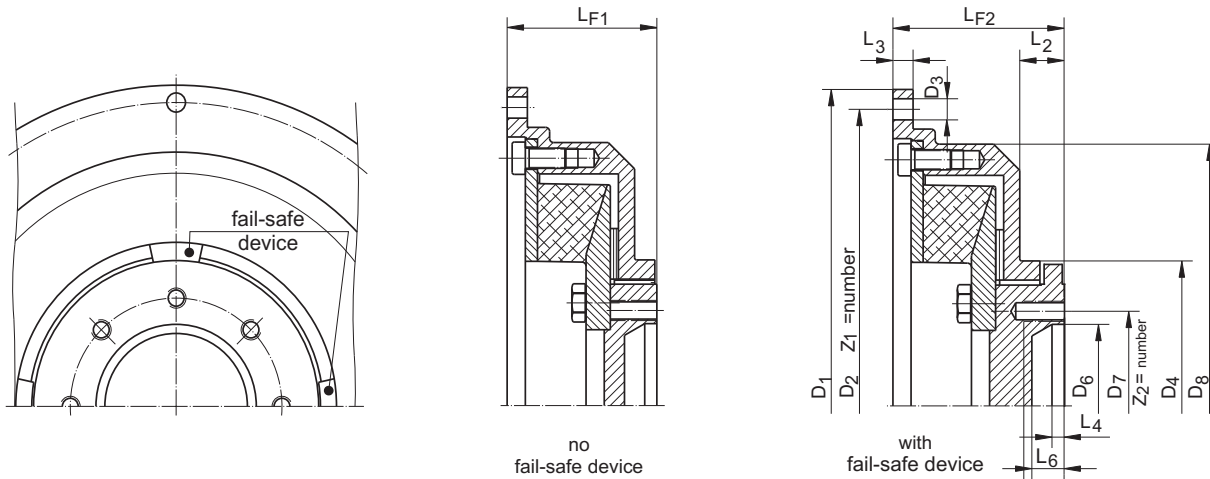

AC-VSK coupling size	Flywheel connection dimensions						Constant velocity shaft connections											J ₁ [kgm ²]	J ₂ ²⁾ [kgm ²]	Total ²⁾ weight [kg]	
	SAE size	D ₁ [mm]	D ₂ [mm]	D ₃ [mm]	Z ₁	D ₄ [mm]	D ₈ [mm]	L ₂ [mm]	L ₃ [mm]	L _{F1} [mm]	L _{F2} [mm]	Size	D ₆ H ₇	D ₇ [mm]	Z ₂ x M	L ₄ [mm]	L ₅ [mm]				L ₆ [mm]
- 15. ¹⁾ .F2	8	263.5	244.5	10.5	6	140	215	18	8	57	68	CV 15	81	94.0	6xM10	6	15	16	0.055	0.009	8.1
	10	314.3	295.3	10.5	8							0.084	9.5								
- 25. ¹⁾ .F2	10	314.3	295.3	10.5	8	144	260	22	10	74	85	CV 15	81	94.0	6xM10	6	20	16	0.148	0.022	15.2
	11.5	352.4	333.4	10.5								0.188	16.6								
- 35. ¹⁾ .F2	10	314.3	295.3	10.5	8	180	279	28	16	78	90	CV 21	90	108.0	6xM12	8	20	20	0.144	0.049	17.0
	11.5	352.4	333.4	10.5								8	0.177	17.2							
- 45. ¹⁾ .F2	11.5	352.4	333.4	10.5	8	180	314	25	26	89	100	CV 30	112	128.0	6xM12	12	23	25	0.281	0.055	22.8
	14	466.7	438.2	13.0								10	0.517	28.4							
- 50. ¹⁾ .F2	14	466.7	438.2	13.0	8	210	352	36	12	103	120	CV 30	112	128.0	6xM12	12	25	25	0.668	0.115	36.2
												CV 32	136	155.5	6xM16		30	26			
- 55. ¹⁾ .F2	14	466.7	438.2	13.0	8	285	417	35	28	115	130	CV 42	144	165.0	8xM16	10	35	26	1.087	0.357	54.7
- 60. ¹⁾ .F2	14	466.7	438.2	13.0	8	300	424	48	25 ³⁾	122	147	CV 42	144	165.0	8xM16	10	35	26	1.100	0.465	62.0
	18	571.5	542.9	17.0	6														15		1.878
- 70. ¹⁾ .F2	18	571.5	542.9	17.0	6	348	510	46	15	134	155	CV 60	216	245.0	8xM20	5	35	25	2.681	0.929	95.7
	21	673.1	641.4	17.0	12														3.747		108.0

1) For the element version see "Technical data" on page 7 • 2) Values without fail-safe device • 3) Centering depth 9 mm

Ordering example: Coupling designation: **AC-VSK 50.WN.F2.14.CV32.DS**

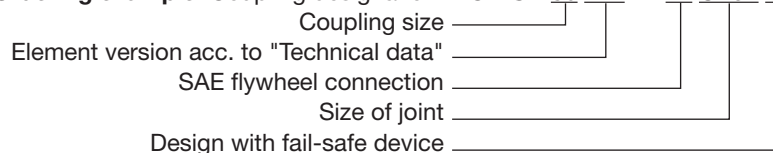

Type AC-VSK...F2.CV for constant velocity shafts
 Engine flywheels with SAE connecting dimensions acc. to J620

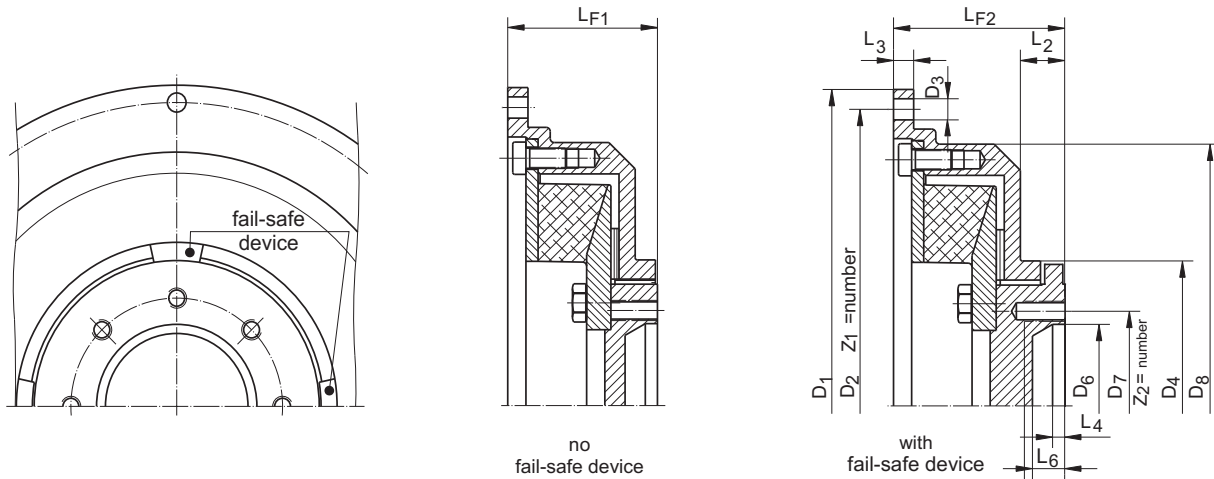

AC-VSK coupling size	Flywheel connection dimensions					Constant velocity shaft connections											J ₁ [lb-in ²]	J ₂ ⁽²⁾ [lb-in ²]	Total weight ⁽²⁾ [lb]		
	SAE size	D ₁ [in]	D ₂ [in]	D ₃ [in]	Z ₁	D ₄ [in]	D ₈ [in]	L ₂ [in]	L ₃ [in]	L _{F1} [in]	L _{F2} [in]	Size	D ₆ H ₇	D ₇ [in]	Z ₂ x M	L ₄ [in]				L ₅ [in]	L ₆ [in]
- 15. ¹⁾ F2	8	10.374	9.626	0.41	6	5.51	8.46	0.71	0.31	2.24	2.68	CV 15	3.189	3.70	6xM10	0.24	0.59	0.63	187.9	30.8	17.9
	10	12.374	11.626	0.41	8							287.0	21.0								
- 25. ¹⁾ F2	10	12.374	11.626	0.41	8	5.67	10.24	0.87	0.39	2.91	3.35	CV 15	3.189	3.70	6xM10	0.24	0.79	0.63	505.7	75.2	33.5
	11.5	13.874	13.126	0.41								642.4	36.6								
- 35. ¹⁾ F2	10	12.374	11.626	0.41	8	7.09	10.98	1.10	0.63	3.07	3.54	CV 21	3.543	4.25	6xM12	0.31	0.79	0.79	492.1	167.4	37.5
	11.5	13.874	13.126	0.41					0.31			604.8	38.0								
- 45. ¹⁾ F2	11.5	13.874	13.126	0.41	8	7.09	12.36	0.98	1.02	3.50	3.94	CV 30	4.409	5.04	6xM12	0.47	0.91	0.98	960.2	187.9	50.3
	14	18.374	17.252	0.51					0.39			1766.7	62.7								
- 50. ¹⁾ F2	14	18.374	17.252	0.51	8	8.27	13.86	1.42	0.47	4.06	4.72	CV 30	4.409	5.04	6xM12	0.47	0.98	0.98	2282.7	393.0	79.9
																					CV 32
- 55. ¹⁾ F2	14	18.374	17.252	0.51	8	11.22	16.42	1.38	1.10	4.53	5.12	CV 42	5.669	6.12	8xM16	0.39	1.38	1.02	3714.5	1219.9	120.7
- 60. ¹⁾ F2	14	18.374	17.252	0.51	8	11.81	16.69	1.89	0.98 ³⁾	4.80	5.79	CV 42	5.669	6.50	8xM16	0.39	1.38	1.02	3758.9	1589.0	136.8
	18	22.500	21.374	0.67					6										0.59		6417.4
- 70. ¹⁾ F2	18	22.500	21.374	0.67	6	13.70	20.08	1.81	0.59	5.28	6.10	CV 60	8.504	6.50	8xM20	0.20	1.38	0.98	9161.4	3174.6	211.2
	21	26.500	25.252	0.67															12		12804.1

1) For the element version see "Technical data" on page 7 • 2) Values without fail-safe device • 3) Centering depth 9 mm

Ordering example: Coupling designation: **AC-VSK 50.WN.F2.14.CV32.DS**

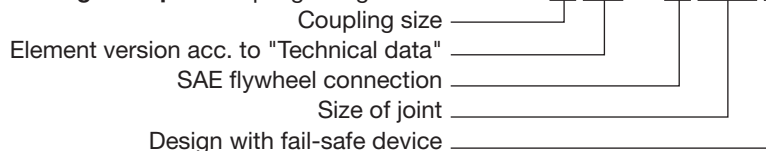

ARCUSAFLEX®-VSK double flange couplings **METRIC/INCH DIMENSIONS**

Type AC-VSK...F1

For mounting between a cardan shaft and related adaptor flange. Alternative flange dimensions are available.

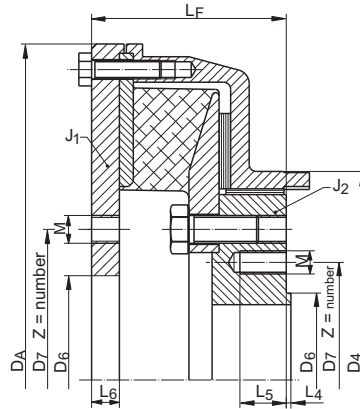

AC-VSK coupling size	D _A [mm]	D ₄ [mm]	L _F [mm]	Flange and cardan shaft connecting dimensions ²⁾							J ₁ [kgm ²]	J ₂ [kgm ²]	Total weight [kg]
				Flange Ø	D ₆ H ₇ /h ₆	D ₇ [mm]	Z x M ²⁾	L ₄ [mm]	L ₅ [mm]	L ₆ [mm]			
- 15. ¹⁾ F1	222	140	60	100	57	84.0	6 x M8	2.0	16	10	0.068	0.0086	10.8
				120	75	101.5	8 x M10						
- 25. ¹⁾ F1	268	144	75	120	75	101.5	8 x M10	2.0	20	10	0.164	0.022	17.5
				120	75	101.5	8 x M10						
- 35. ¹⁾ F1	290	180	84	150	90	130.0	8 x M12	2.5	23	12	0.222	0.048	23.5
				150	90	130.0	8 x M12						
- 45. ¹⁾ F1	320	180	92	150	90	130.0	8 x M12	2.5	23	12	0.408	0.063	33.3
				150	90	130.0	8 x M12						
- 50. ¹⁾ F1	360	210	108	150	90	130.0	8 x M12	2.5	25	14	0.659	0.114	42.7
				180	110	155.5	8 x M14						
- 55. ¹⁾ F1	475	285	130	180	110	155.5	8 x M14	3.0	25	15	1.711	0.350	73.0
				225	140	196.0	8 x M16						
				250	140	218.0	8 x M18						
- 60. ¹⁾ F1	485	300	137	180	110	155.5	8 x M14	3.0	25	20	1.796	0.464	83.4
				225	140	196.0	8 x M16						
				250	140	218.0	8 x M18						
- 70. ¹⁾ F1	580	348	154	250	140	218.0	8 x M18	4.0	30	20	3.965	0.945	127.0
				285	175	245.0	8 x M20						
- 85. ¹⁾ F1	685	440	180	285	175	245.0	8 x M20	5.0	35	20	10.234	2.231	211.7
				315	175	280.0	8 x M22						

AC-VSK coupling size	D _A [in]	D ₄ [in]	L _F [in]	Flange and cardan shaft connecting dimensions ²⁾							J ₁ [lb-in ²]	J ₂ [lb-in ²]	Total weight [lb]
				Flange Ø	D ₆ H ₇ /h ₆	D ₇ [in]	Z x M ²⁾	L ₄ [in]	L ₅ [in]	L ₆ [in]			
- 15. ¹⁾ F1	8.740	5.512	2.362	3.937	2.244	3.307	6 x M8	0.079	0.630	0.394	232.4	29.4	23.8
				4.724	2.953	3.996	8 x M10						
- 25. ¹⁾ F1	10.551	5.669	2.953	4.724	2.953	3.996	8 x M10	0.079	0.787	0.394	560.4	75.2	38.6
				4.724	2.953	3.996	8 x M10						
- 35. ¹⁾ F1	11.417	7.087	3.307	4.724	2.953	3.996	8 x M10	0.079	0.787	0.472	758.6	164.0	51.9
				5.906	3.543	5.118	8 x M12						
- 45. ¹⁾ F1	12.598	7.087	3.622	5.906	3.543	5.118	8 x M12	0.098	0.906	0.472	1394.2	215.3	73.5
				5.906	3.543	5.118	8 x M12						
- 50. ¹⁾ F1	14.173	8.268	4.252	5.906	3.543	5.118	8 x M12	0.098	1.181	0.551	2251.9	389.6	94.2
				7.087	4.331	6.122	8 x M14						
- 55. ¹⁾ F1	18.701	11.220	5.118	7.087	4.331	6.122	8 x M14	0.118	1.181	0.591	5846.8	1196.0	161.1
				8.858	5.512	7.717	8 x M16						
				9.843	5.512	8.583	8 x M18						
- 60. ¹⁾ F1	19.094	11.811	5.394	7.087	4.331	6.122	8 x M14	0.118	1.181	0.787	6137.2	1585.6	184.1
				8.858	5.512	7.717	8 x M16						
				9.843	5.512	8.583	8 x M18						
- 70. ¹⁾ F1	22.835	13.701	6.063	9.843	5.512	8.583	8 x M18	0.157	1.181	0.787	13549.1	3229.2	280.3
				11.220	6.890	9.646	8 x M20						
- 85. ¹⁾ F1	26.969	17.323	7.087	11.220	6.890	9.646	8 x M20	0.197	1.378	0.787	34971.3	7623.7	467.2
				12.402	6.890	11.024	8 x M22						

1) For the element version see "Technical data" on page 7 • 2) Alternative connecting dimensions and threads on request

Ordering example: Coupling designation: **AC-VSK 50.WN.F1.150.M12.180**

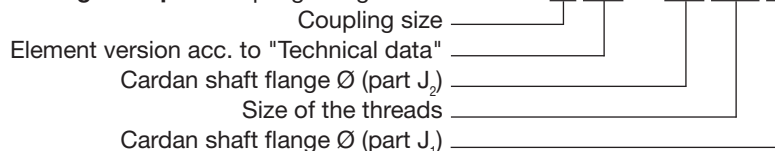

Type AC-VSK...F1W

To connect a shaft to a cardan shaft

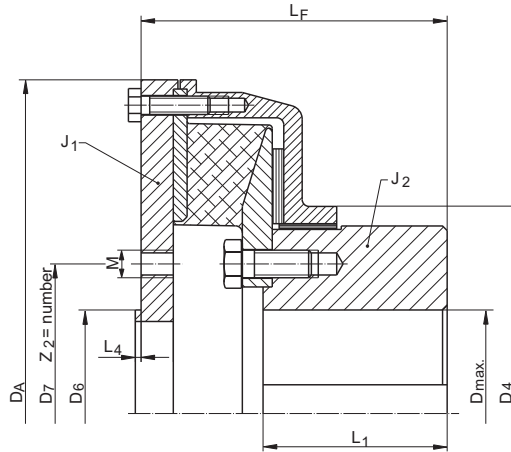

AC-VSK coupling size	D _A [mm]	D ₄ [mm]	L _{max} [mm]	L ₁ [mm]	L _F [mm]	Cardan shaft connecting dimensions ²⁾					J ₁ [kgm ²]	J ₂ [kgm ²]	Total weight [lb]
						Flange Ø	D ₆ h ₆	D ₇ [mm]	Z ₂ x M ²⁾	L ₄ [mm]			
- 15. ¹⁾ F1W	222	140	60	65	104	100	57	84.0	6 x M8	2.0	0.068	0.016	14.3
						120	75	101.5	8 x M10				
- 25. ¹⁾ F1W	268	144	60	65	114	120	75	101.5	8 x M10	2.0	0.164	0.028	20.7
- 35. ¹⁾ F1W	290	180	90	80	133	120	75	101.5	8 x M10	2.0	0.222	0.073	30.0
						150	90	130.0	8 x M12				
- 45. ¹⁾ F1W	320	180	90	80	139	150	90	130.0	8 x M12	2.5	0.408	0.088	39.9
- 50. ¹⁾ F1W	360	210	100	100	171	150	90	130.0	8 x M12	2.5	0.659	0.168	54.0
						180	110	155.5	8 x M14				
- 55. ¹⁾ F1W	475	285	120	140	230	180	110	155.5	8 x M14	3.0	1.711	0.666	110.0
						225	140	196.0	8 x M16				
						250	140	218.0	8 x M18				
- 60. ¹⁾ F1W	475	300	120	140	225	180	110	155.5	8 x M14	3.0	1.796	0.760	113.0
						225	140	196.0	8 x M16				
						250	140	218.0	8 x M18				
- 70. ¹⁾ F1W	580	348	150	170	275	250	140	218.0	8 x M18	4.0	3.965	1.737	190.0
						285	175	245.0	8 x M20				

AC-VSK coupling size	D _A [in]	D ₄ [in]	L _{max} [in]	L ₁ [in]	L _F [in]	Cardan shaft connecting dimensions ²⁾					J ₁ [lb-in ²]	J ₂ [lb-in ²]	Total weight [lb]
						Flange Ø	D ₆ h ₆	D ₇ [in]	Z ₂ x M ²⁾	L ₄ [in]			
- 15. ¹⁾ F1W	8.740	5.512	2.362	2.559	4.094	3.937	2.244	3.307	6 x M8	0.079	232.4	54.7	31.6
						4.724	2.953	3.996	8 x M10				
- 25. ¹⁾ F1W	10.551	5.669	2.362	2.559	4.488	4.724	2.953	3.996	8 x M10	0.079	560.4	95.7	45.7
- 35. ¹⁾ F1W	11.417	7.087	3.543	3.150	5.236	4.724	2.953	3.996	8 x M10	0.079	758.6	249.5	66.2
						5.906	3.543	5.118	8 x M12				
- 45. ¹⁾ F1W	12.598	7.087	3.543	3.150	5.472	5.906	3.543	5.118	8 x M12	0.098	1394.2	300.7	88.1
- 50. ¹⁾ F1W	14.173	8.268	3.937	3.937	6.732	5.906	3.543	5.118	8 x M12	0.098	2251.9	547.1	119.2
						7.087	4.331	6.122	8 x M14				
- 55. ¹⁾ F1W	18.701	11.220	4.724	5.512	9.055	7.087	4.331	6.122	8 x M14	0.118	5846.8	2275.8	242.8
						8.858	5.512	7.717	8 x M16				
						9.843	5.512	8.583	8 x M18				
- 60. ¹⁾ F1W	18.701	11.811	4.724	5.512	8.858	7.087	4.331	6.122	8 x M14	0.118	6137.2	2597.1	249.4
						8.858	5.512	7.717	8 x M16				
						9.843	5.512	8.583	8 x M18				
- 70. ¹⁾ F1W	22.835	13.701	5.906	6.693	10.827	9.843	5.512	8.583	8 x M18	0.157	13549.1	5935.6	419.4
						11.220	6.890	9.646	8 x M20				

1) For the element version see "Technical data" on page 7 • 2) Alternative connecting dimensions and threads on request

Ordering example: Coupling designation: **AC-VSK 50.WN.F1W.150**

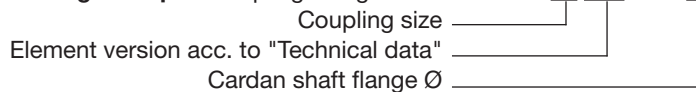

Assembly and maintenance instructions

General

The highly flexible ARCUSAFLEX®-AC-VSK coupling is well suited for installation with drive shafts because of its internal support by the radial and thrust bearings. The use of appropriate bearing materials makes the AC-VSK coupling maintenance-free.

The coupling element is suitable for ambient temperatures of -40 °F (-40 °C) to 176 °F (80 °C).

All couplings meet the balancing grade of G=16 for n=1500 rpm acc. to ISO 1940.

Assembly

Prior to the assembly, all parts of the coupling must be cleaned. All closely toleranced surfaces are protected with Tectyl preservative ex works. These surfaces must be cleaned with a suitable solvent prior to installation of the coupling. The solvent which is used for cleaning must not contact the rubber.

All bolted connections of the coupling should be tightened with a torque wrench and the correct bolt tightening torque must be checked. The prescribed bolt tightening torques must be precisely observed. As standard the values shown below are valid except when other values are specified. Values stated on the specific design drawing take precedence.

The coupling in its fully assembled condition is bolted to the engine flywheel and the full bolt tightening torque is applied. Then the flange of the drive shaft is bolted to the flange of the coupling.

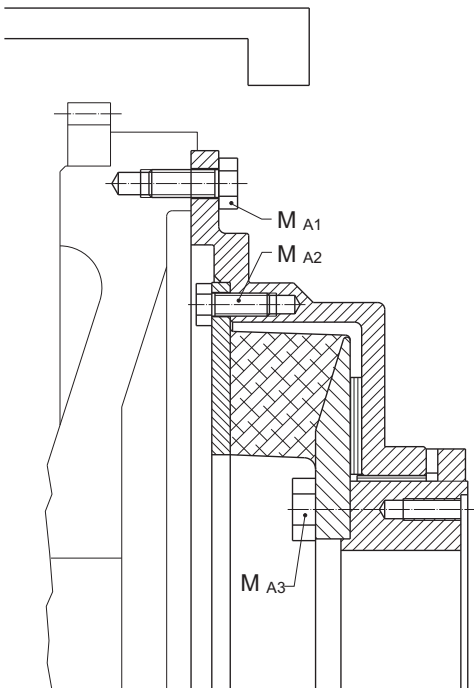

Tightening torques for the bolted flange connection to the engine flywheel (bolt grade 8.8, lightly oiled¹⁾)

Flywheel SAE	6 1/2	7 1/2	8	10	11 1/2	14	16	18	21
Metric bolts	M8		M10			M12		M16	
M_{A1} [lb-in]	221		442			752		1860	
M_{A1} [Nm]	25		50			85		210	
Inch-bolts	⁵ / ₁₆ - 18		³ / ₈ - 16			¹ / ₂ - 13		⁵ / ₈ - 11	
M_{A1} [lb-in]	212		372			903		1800	
M_{A1} [Nm]	24		42			102		203	

Tightening torques for AC-VSK-element bolted connections (lightly oiled¹⁾)

AC-VSK Size	15	25	35	45	50	55	60	70	85
Bolt size	M8	M10	M8	M10	M10	M12	M12	M12	M16
Bolt grade	8.8	8.8	8.8	8.8	8.8	8.8	10.9	8.8	8.8
M_{A2} [lb-in]	221	442	221	442	442	760	1062	760	210
M_{A2} [Nm]	25	50	25	50	50	86	120	86	1860
Bolt size	M10	M10	M12	M12	M16	M16	M16	M20	M20
Bolt grade	10.9	10.9	10.9	10.9	10.9	10.9	10.9	10.9	10.9
M_{A3} [lb-in]	610	610	1062	1062	2610	2610	2610	5130	5130
M_{A3} [Nm]	69	69	120	120	295	295	295	580	580

1) Values are reduced by 20% for bolts with additional lubrication.

Disassembly

First the drive shaft must be disconnected from the coupling. Then the coupling is unbolted from the engine flywheel and lifted out. To take the coupling apart, the bolt connections of the rubber elements must be released.

Safety precautions

It is the customer's and user's responsibility to observe the national and international safety rules and laws. Proper safety devices must be provided for the coupling to prevent accidental contact.

Check all bolted connections for the correct tightening torque and fit after a short running period preferably after a test run.

General maintenance and wear inspection

Within the established periodic maintenance and inspections of other parts of the installation, the coupling should regularly be visually inspected. Generally the internal bearing support in the coupling is maintenance-free. If there are any conspicuous symptoms a closer inspection is necessary.

The coupling must be disassembled according to the instructions. The visible outside and inside diameter of the rubber part of the removed coupling element has to be checked for possible cracks and separations. If there is any damage the coupling element must be replaced. At this time it is advisable to replace the bearings as well.

The thrust bearing (friction disc) and the radial bearing (bearing bushing) must be replaced if rough running is observed, or if a tilting clearance at the coupling is detectable. The thrust bearing (friction disc) must be replaced if there is a relative axial play between the drive shaft flange and the housing of the coupling. The radial bearing (bearing bushing) must be replaced if the radial wear R is exceeded. For this the radial relocation of the drive shaft flange to the coupling housing can be measured (see picture). The values shown in the table below serve as a guide. The running surfaces of the bearings must not be damaged. No reworking of the precision surfaces is advisable, if damaged these particular parts must be replaced.

During maintenance the coupling must be thoroughly cleaned.

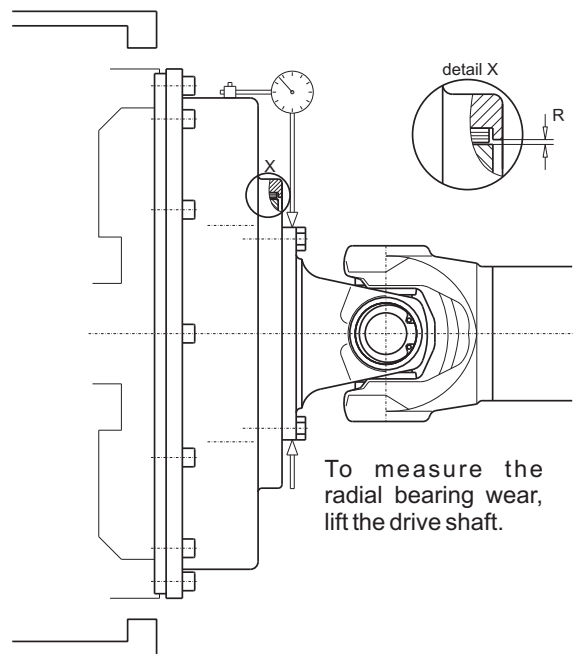

Limits for wear of the friction disc and bearing bush

AC-VSK size	15	25	35	45	50	55	60	70	85
Thrust bearing friction disc thickness [in]	0.10	0.10	0.10	0.10	0.10	0.10	0.20	0.24	0.30
Thrust bearing friction disc thickness [mm]	2.5	2.5	2.5	2.5	2.5	2.5	5	6	7.5
Permissible axial wear [in]	0.024	0.024	0.024	0.028	0.028	0.028	0.028	0.031	0.031
Permissible axial wear [mm]	0.6	0.6	0.6	0.7	0.7	0.7	0.8	0.8	0.8
Radial bearing bush thickness [in]	0.16	0.16	0.20	0.20	0.20	0.20	0.20	0.20	0.20
Radial bearing bush thickness [mm]	4	4	5	5	5	5	5	5	5
Permissible radial wear R [in]*	0.012	0.012	0.012	0.012	0.012	0.012	0.031	0.031	0.031
Permissible radial wear R [mm]*	0.3	0.3	0.3	0.3	0.3	0.3	0.8	0.8	0.8

*) The wear of the bearing bush is equal to half of the measured radial wear R

During all operation phases the coupling has to run silently and vibration-free. Any deviation from this smooth behaviour during running indicates the need for closer inspection, repair or replacement.

In general a rebalancing of the coupling after replacing worn parts is not necessary. If rough running is observed after the repair, a further inspection is necessary and balancing may be required.



Dipl.-Ing. Herwarth Reich GmbH

Vierhausstraße 53 • 44807 Bochum / Germany
Postfach 10 20 66 • 44720 Bochum / Germany

Telefon +49 (0) 234 9 59 16 - 0
Telefax +49 (0) 234 9 59 16 - 16

E-Mail: mail@reich-kupplungen.de
www.reich-kupplungen.de

Reich USA Corporation

300 Route 17 South - Suite H
Mahwah, New Jersey 07430 USA

Phone (201) 684 9400
FAX (201) 684 9401

E-mail: sales@reichusa.com
Website: www.reichusa.com